



# FCU<sup>47</sup> SAFESCREEN SYSTEM INSTALLATION

## PACKING LIST FDS 0547

Product:

1 - Safescreen Receiver	x 1
2 - Safescreen Transmitter	x 1
3 - Interface Unit (See Reverse)	x 1
4 - Cable Assembly	x 2
5 - Mounting Bracket	x 2
6 - Installation Guide	x 1

Accessories:

7 - M5 x 10mm Screw (standard)	x 10
8 - M5 Washer Plain	x 10
9 - M5 Washer Shakeproof	x 10
10 - M4 x 20mm Screw (thread forming)	x 24
11 - M4 Washer Plain (large diameter)	x 24
12 - M4 Washer Shakeproof	x 24
13 - Drill Bit 3.6mm	x 1
14 - #10 x 13mm Screw (self drill)	x 14
15 - Spacer Block	x 1
16 - Cable Clips	x 6
17 - Nytie	x 8
18 - Self adhesive pads	x 4
19 - Cable retainer	x 2

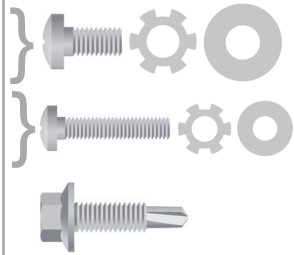

## Side Opening

## Center Opening

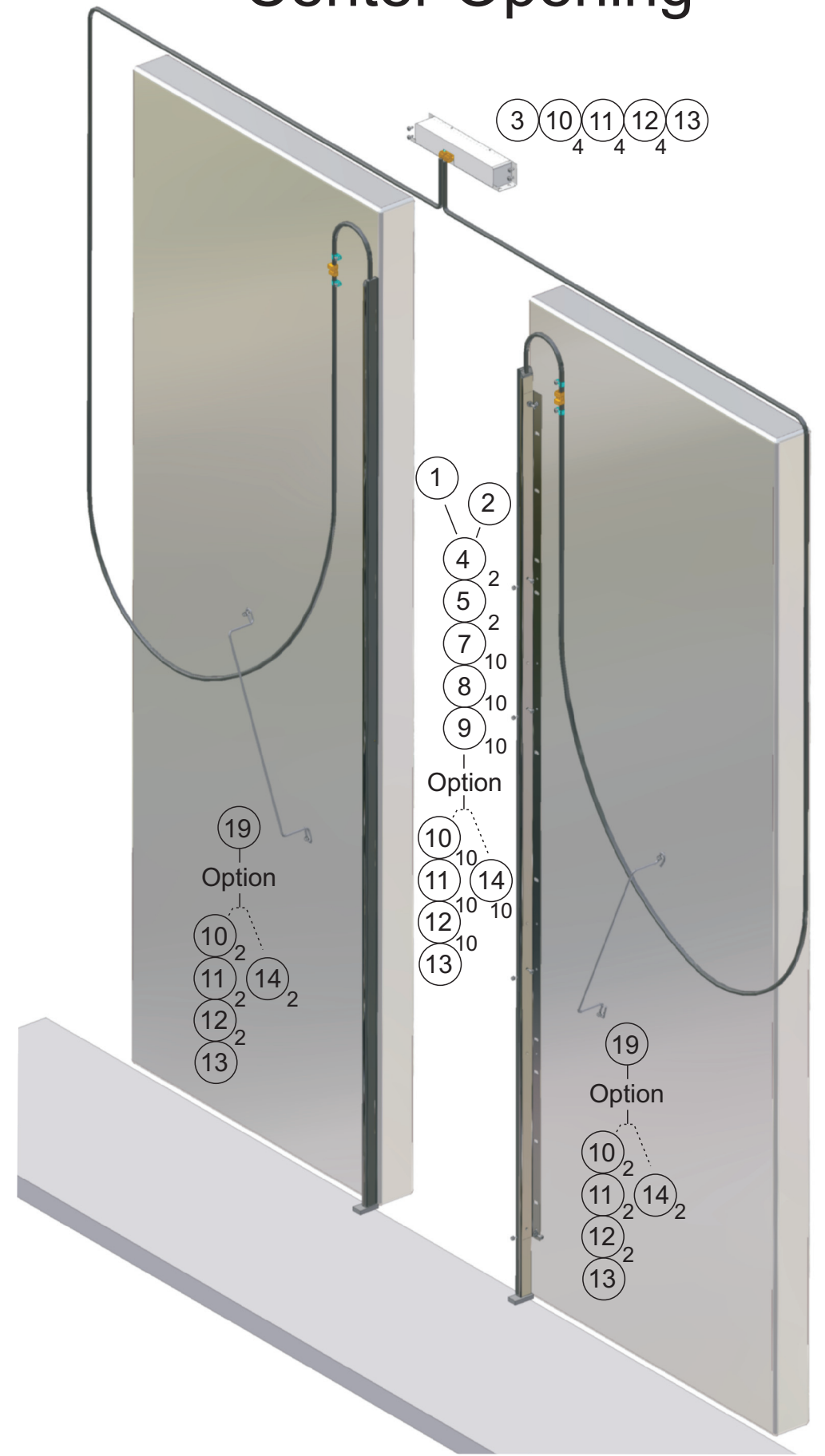
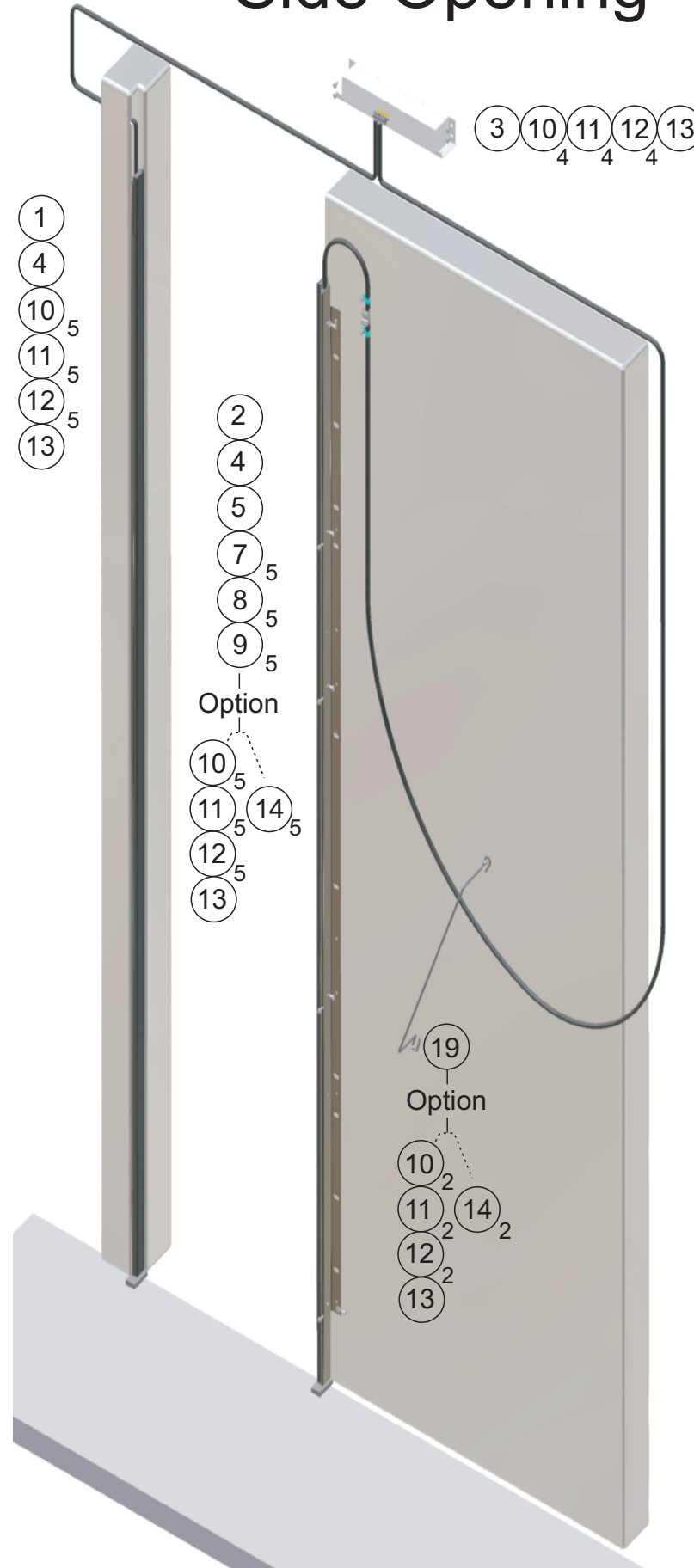

- 16
- 10<sub>2</sub>
- 11<sub>2</sub>
- 12<sub>2</sub>
- 13

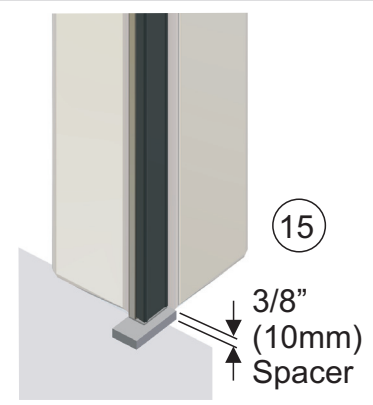
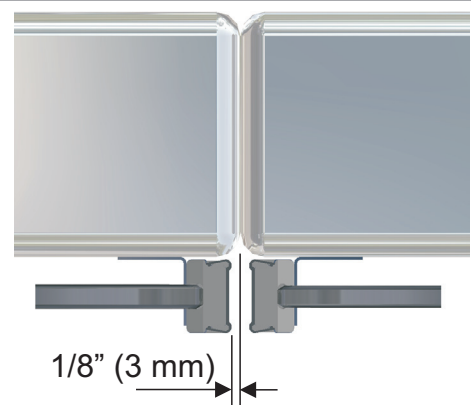
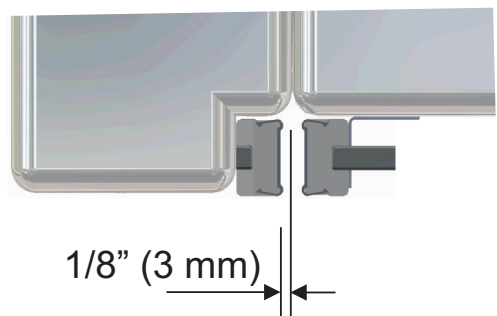



# FCU<sup>47</sup> SAFESCREEN SYSTEM INSTALLATION

**INDICATOR LOCATIONS**

**FINAL CHECK & TROUBLESHOOTING**

INTERFACE UNIT		
Indicator	Status	Action
Green	On - Supply OK	Check AC (DC) Supply
	Off - No Supply	
Red	Off - No Obstruction (relay energised)	Remove obstruction
	On - Obstruction (beam broken)	
SAFESCREEN TRANSMITTER		
Indicator	Status	Action
Green	On - Supply OK	Check AC (DC) Supply & Cables for damage
	Off - No Supply	
SAFESCREEN RECEIVER		
Indicator	Status	Action
Green	On - Supply OK	Check AC (DC) Supply & Cables for damage
	Off - No Supply	
Red	Off - No Obstruction	Remove obstruction
	On - Obstruction (beam broken)	
	Flash - Single Beam Override Active	

## INTERFACE UNIT - ADDITIONAL INFORMATION

### INTERFACE UNIT - BUZZER / NUDGING FEATURES

The buzzer/nudging power supply offers a variety of features to facilitate elevator door control set-up during continuous beam interruption.

As with our standard power supply a simple relay activates whenever beam paths are blocked.

In addition to the "standard" relay an additional relay will activate after beam paths have been continuously blocked for a pre-determined period of time. This "time-out period" can be determined by the installer during set-up by way of a variable potentiometer mounted on the power supply circuit board.

As elevator controllers have become more intelligent over time, Formula have included a relay configuration option that may be invoked through "Switch #3".

For older elevator systems, door speed/power are typically a door-operator controlled function. The door controller simply controls the instructions to open or close doors. Therefore, if a constant obstruction is detected, the "standard" relay will activate as normal, and remains activated until the "time-out" relay switches.

On older elevators, the "time-out" relay would switch in a resistor to effectively reduce the motor power to slow-down the closing speed of the doors. However, with the beam-path obstruction still present, the "standard" relay would still be activated, therefore the controller would still not know that the doors can now be instructed to close.

Switch #3 resolves this conflict. If switch #3 is in the "on" position, as soon as the "time-out" relay activates, the "standard" relay immediately reverts to a "no obstruction" state, even though an obstacle remains. Therefore, the "time-out" relay switches in the door speed resistor on the operator, and at the same time the door controller sees an "all clear" from the "standard" relay, thereby allowing the doors to be instructed to close.

Leaving switch #3 in the "off" position may be a requirement for more sophisticated controllers that can invoke slow-speed closing from the "time-out" relay and can ignore the "standard" relay signal.

In order to see this feature in operation, let a power supply time-out (this can be done bench-mounted without edges connected), and turn switch #3 on and off. This should activate and de-activate the "standard" relay.

### EVENT SEQUENCE - BUZZER / NUDGING OPERATION

Event	Standard Relay (Switch 3 OFF)	Standard Relay (Switch 3 ON)	Time-out Relay
No obstruction	Dormant	Dormant	Dormant
Obstruction before time-out period	Active	Active	Dormant
Obstruction after time-out period	Active	Dormant	Active

### Contacts:

Formula online: <http://www.formula-systems.com>

Customer Care: North America: 1-866 952 9200 (toll free)  
Others Countries: +44 (0)1865 882442

## INTERFACE UNIT - DETAILS

### INTERFACE UNIT - BUZZER / NUDGING FEATURES

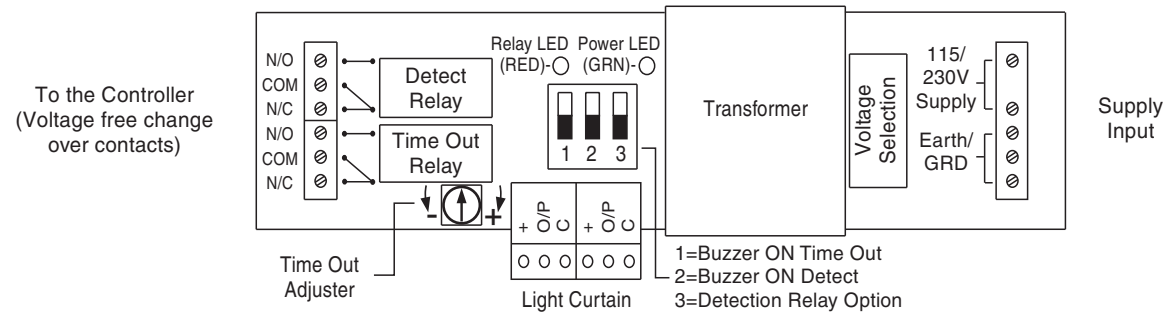

### INTERFACE UNIT - STANDARD FEATURES

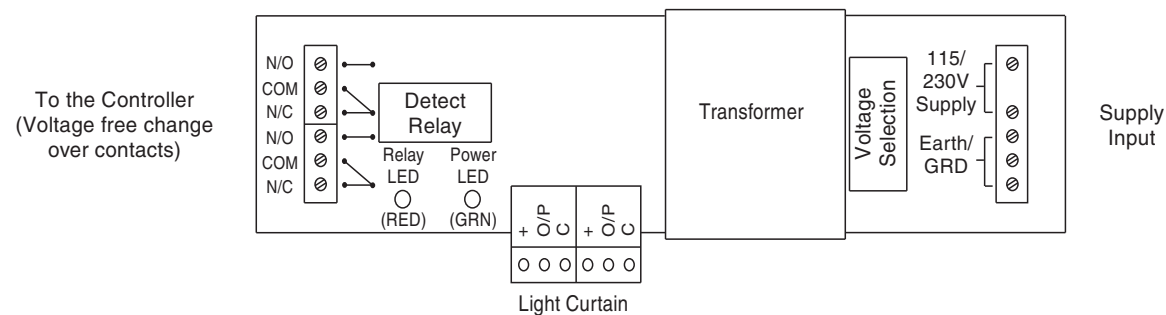

## FIELD WIRING

Cable insulation to be rated 60°C minimum.  
Copper conductors must be used.

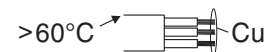

Nominal tightening torque value 0.45Nm



Route cable through the holes provided adjacent to the point of connection.